

KTM-100 Series

Electromagnetic Flow meter
Suitable for Small Flow rate

FEATURE

- Its design with a light weight enables to easily install in a narrow place.
- No maintenance is necessary because no driving parts, impediments, or wear.
- Special design suitable for measuring small flow rates
- High durability to most of corrosive or abrasive fluids
- Provides superb stability and accuracy for a long time
- Maintains a stable accuracy even at a site with a high level of noise and vibration
- Specific installation length and various sanitary connection options available

APPLICATIONS

- ▶ Water and sewage industry
 - Water extraction and irrigation facilities
 - Water circulation and treatment facility
- ▶ Machinery and Equipment (OEM)
 - For rotary and linear injection machines
 - Fast and accurate process (Batching), mixing and input
- ▶ Food and Beverage industry
 - Various conductive liquids (water, soft drinks, milk, beer, juice, etc.)
- ▶ Mineral and Mining
 - Similar in use to a cement
- ▶ Water treatment industry
 - Check pump and water source

■ KTM-100 General Specifications

Size	DN 2 - DN 25
Process Connection	PT
Measuring Range	0.1 L/min – 300 L/min
Flow Velocity	0.3 m/s – 10 m/s
Accuracy	±1.0 % F.S
Ambient Temperature	-10 °C ~ 60 °C
Conductivity	Over 5 μ s / cm
Power Supply	DC 24 V (3 -Wire)
Output	Frequency / DC 4-20 mA
Body Material	Aluminium

■ STRUCTURAL DRAWING

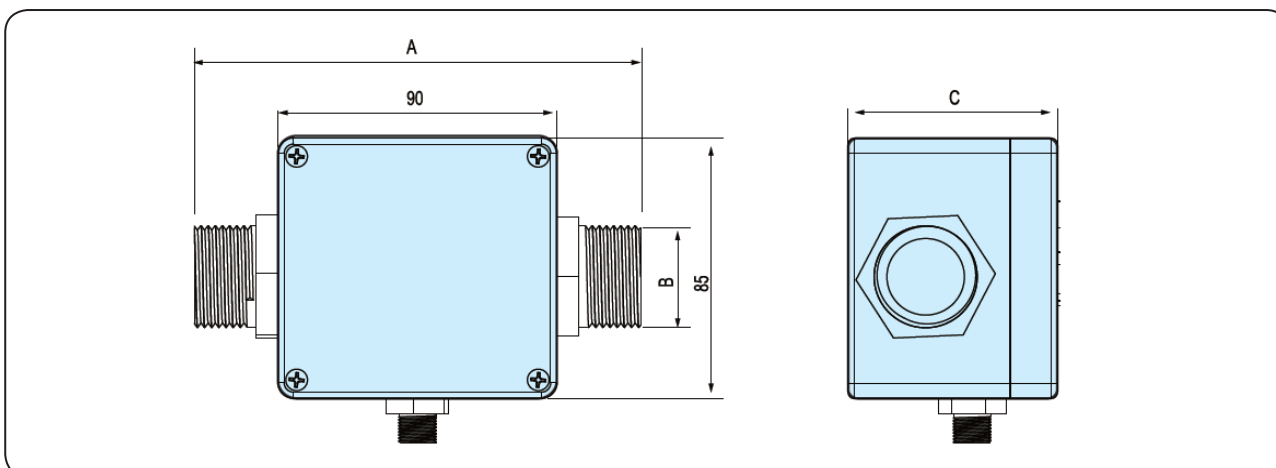

■ FLOW RANGES

Size	Flow Range		Male Thread
	Standard	Special	
DN2	0.1 - 1	0.1 - 2	PT 3/8"
DN3	0.2 - 2	0.2 - 4	
DN4	0.4 - 4	0.4 - 8	
DN6	0.8 - 8	0.8 - 16	
DN8	1.5 - 15	1.5 - 30	PT 1/2"
DN10	2 - 20	2 - 40	
DN15	5 - 50	5 - 100	
DN20	9 - 90	9 - 180	PT 3/4"
DN25	15 - 150	15 - 300	PT 1"

■ DIMENSIONS

Size	A (mm)	B (inch)	C (mm)
DN2	130	PT 3/8	67.5
DN3		PT 3/8	
DN4		PT 3/8	
DN6	140	PT 3/8	
DN8		PT 1/2	
DN10	150	PT 1/2	
DN15		PT 1/2	
DN20		PT 3/4	
DN25	160	PT 1	